



(12) **United States Patent**  
PUBLIC et al.

(10) **Patent Number: 6,543,210 B1**  
(45) **Date of Patent: Nov. 9, 2001**

(54) **PORTABLE APPARATUS FOR SITTING**

5,064,247 11/1991 Clark et al.  
3,336,078 8/1961 Haley  
2,575,221 11/1951 Horner et al.

(75) **Inventors: John Q. Public, Jane B. Doe,**  
**both of New York, NY**

(73) Assignee: **Acme Seating,**  
**San Jose, CA**

*Primary Examiner Benita Millman*

(21) Appl. No.: **09/876,543**

(57) **ABSTRACT**

(22) **Filed: May 28, 1999**

**Related U.S. Application Data**

(60) Provisional application No. 60/999,111 May 28, 1998.

(51) **Int. Cl.<sup>6</sup> ..A47C 007/02**

(52) **U.S. Cl. .297/452.1**

(58) **Field of Search .297/452.1,440.2**

A portable apparatus for use while sitting. The apparatus includes a planar surface or seat with at least three elongate members or legs attached to one side of the planar surface or seat. The elongate members or legs are generally parallel to each other and below the planar surface or seat in use. The apparatus may include a support member or back that is attached to the opposite side of the planar surface or seat and extends upward in use.

(56) **References Cited**

U.S. PATENT DOCUMENTS

6,250,718 6/2001 Newhouse et al.

**7 Claims, 2 Drawing Sheets**

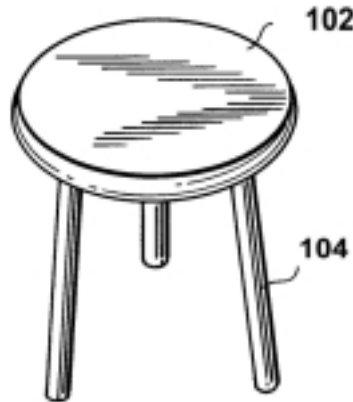

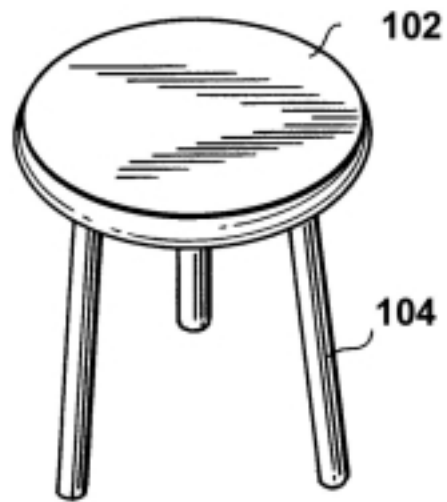

100

FIG. 1

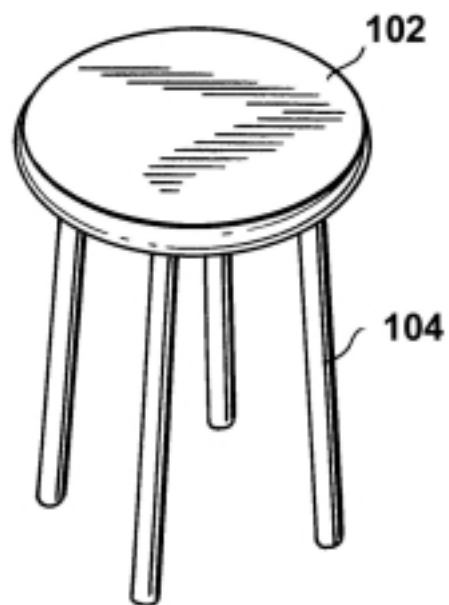

FIG. 2

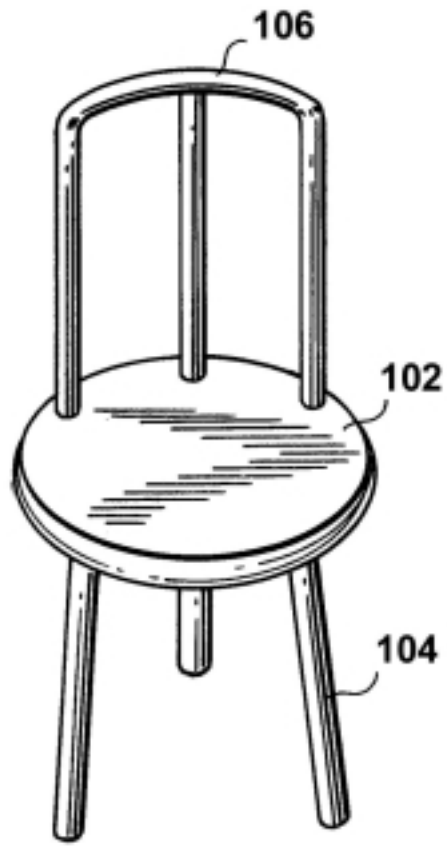

FIG.3

1  
PORTABLE APPARATUS FOR  
SITTING

BACKGROUND OF THE INVENTION

1. Field of the Invention

The present invention relates to an apparatus for supporting a human in a sitting position, and more particularly to an apparatus that is portable and stable.

2. Background of Related Art

As known in the prior art, a person walking around their environment and from place to place can become tired and want to rest. One way to rest is to lie on the ground. However, in many areas the ground is dirty and people usually want to rest without becoming dirty. In some areas, rocks, logs and stumps are abundant and people have found that placing their buttock on these rocks, logs and stumps allows them to rest without lying on the ground and becoming dirty. People using this resting technique often say that they "sit" on the rocks, logs or stumps, or are "sitting," and the position when their buttock is on the rock, log or stump is known as a sitting position. In some areas there are very few rocks, logs and stumps and so humans find it difficult to sit. This can be a particular problem in areas with homes, where the rocks, logs and stumps are used to construct the home, and are no longer available for sitting.

Even in areas where rocks, logs and stumps are plentiful, they may not be concentrated in the locations where people want to sit, such as when they gather together as a group around a fire and tell stories.

What is needed is an apparatus that people can use for sitting in all areas, such as areas with few rocks, logs and stumps. What is also needed is an apparatus that is portable so people can easily carry or

2

move the apparatus from place to place, allowing them to sit with others in groups.

SUMMARY OF THE INVENTION

In one embodiment, the invention provides an apparatus that includes a substantially planar surface or seat with a first and a second surface, and at least three elongate members or legs. The members or legs each have a first end and a second end. The first ends are connected to the first surface of the planar surface and are oriented with respect to the planar surface such that the legs are substantially perpendicular to the planar surface and are substantially parallel to each other. The length of the legs is approximately equal to the distance between the knee and the ankle of an adult leg. The planar surface is approximately equal in area to the area of the back surface of an adult buttock.

In one embodiment, the apparatus includes three elongate members or legs.

In one embodiment, the apparatus includes four elongate members or legs.

In one embodiment, the apparatus includes a support member or back that is attached to the second surface of the planar surface or seat.

DESCRIPTION OF THE DRAWINGS

The foregoing features and other aspects of the invention are explained in the following description taken in conjunction with the accompanying figures wherein:

FIG. 1 illustrates one embodiment of the invention with three elongate members, or legs attached to a planar surface or seat;

FIG. 2 illustrates one embodiment of the invention with four elongate members or legs attached to a planar surface or seat; and

5

10

15

20

25

30

35

40

45

3

FIG. 3 illustrates one embodiment of the invention with a support member or back attached to a planar surface or seat.

It is understood that the drawings are for illustration only and are not limiting.

**DETAILED DESCRIPTION OF THE DRAWINGS**

Referring first to FIG. 1, one embodiment of apparatus 100 of the invention includes a planar surface or "seat" 102. Planar surface or seat 102 is preferably formed of wood, and in some embodiments planar surface or seat 102 is round, rectangular or square.

Elongate members or "legs" 104 of apparatus 100 have two ends, with one end connected to planar surface 102. In the embodiment that is illustrated in FIG. 1, apparatus 100 has three elongate members 104. In the embodiment that is illustrated in FIG. 2, apparatus 100 has four elongate members 104.

Although not illustrated in the figures, in one embodiment, elongate members 104 are first formed as separate pieces and then they are joined to planar surface 102. In another embodiment, elongate members 104 and planar surface 102 are all formed together. In one embodiment, when elongate members 104 and planar surface 102 are formed as separate pieces and then joined, the connection between elongate members 104 and planar surface 102 is generally rigid and semi-permanent, such as with glue. In another embodiment elongate members 104 are generally rigid and easily connected and removed from planar surface 102, such as by threading.

The physical relationship between elongate members 104 and planar surface 102 is such that elongate members 104 are generally parallel to each other and also perpendicular to planar surface 102. This configuration is illustrated in FIGs. 1 and 2. It is possible that elongate members

4

104 are not generally parallel to each other. However, when elongate members are strongly divergent (i.e., form a wide angle) the configuration has less strength and may result in breakage of elongate members 104.

As illustrated in FIGs. 1 and 2, apparatus 100 includes at least three elongate members. When fewer than three elongate members were tried, it was found that apparatus 100 was not particularly stable and resting was therefore difficult. With three elongate members, as illustrated in FIG. 1, apparatus 100 is very stable and it has been found that as long as the length of the elongate members is generally the same, slight differences in length do not matter. With four elongate members, as illustrated in FIG. 2, apparatus 100 is even more stable, although it has been found that a substantially uniform length of elongate members 104 is important. Therefore, there are relative advantages and disadvantages for each of the three "leg" and four "leg" embodiments illustrated in FIGs. 1 and 2 respectively.

Referring now to FIG. 3, another embodiment of apparatus 100 includes a support member 106. In this embodiment, support member 106 is connected to the side of planar surface 102 that is opposite the side of planar surface 102 where elongate members 104 are connected. It has been found that by configuring support member 106 so that it extends in a generally opposite direction from the elongate members, a person can place or lean their back against the support member while resting. This has been shown to significantly enhance the resting and sitting experience. For this reason, support member 106 is also termed a "back".

For ease of description herein, the embodiment with only legs (FIGs. 1 and 2) is called a stool, and the embodiment with legs and a back (FIG. 3) is called a chair.

In normal sitting use, apparatus 100 is oriented as illustrated in FIGs. 1 and

5

10

15

20

25

30

35

40

45

5

2, with the elongate members below planar surface 102. In this configuration, the ends of elongate members 104 that are furthest from planar surface 102 contact the ground. This elevates planar surface 102 above the ground, and also positions planar surface 102 in a generally horizontal or parallel orientation to the ground.

In order for apparatus 100 to be most effective when used for sitting, there are certain preferred sizes or dimensions for planar surface 102 and elongate members 104. In one embodiment, the area of planar surface or seat 102 is generally about the same area as the area of an adult buttock. In one embodiment, the length of elongate members 104 is generally about the same as the distance from the knee to the ankle of the leg of an adult. This is one of the reasons for using the term "leg" to apply to elongate members 104. Of course, if apparatus 100 is constructed for use by children, the length of leg 104 may be somewhat shorter. The same considerations apply for the area of planar surface 102.

Although illustrative embodiments have been described herein in detail, it should be noted and will be appreciated by those skilled in the art that numerous variations may be made within the scope of this invention without departing from the principle of this invention and without sacrificing its chief advantages.

Unless otherwise specifically stated, the terms and expressions have been used herein as terms of description and not terms of limitation. There is no intention to use the terms or expressions to exclude any equivalents of features shown and described or portions thereof and this invention should be defined in accordance with the claims that follow.

**We claim:**

1. An apparatus comprising:

6

a substantially planar surface with a first and a second surface; and

at least three elongate members, the members each having a first end and a second end, the first ends connected to the first surface of the planar surface and oriented with respect to the planar surface such that the elongate members are substantially perpendicular to the planar surface and the elongate members are substantially parallel to each other.

5

10

15

20

25

30

35

40

45

2. An apparatus according to claim 1, further comprising a support member connected to the second surface of the planar surface and oriented in a direction generally parallel to the elongate members.

3. An apparatus according to claim 1, further comprising exactly three elongate members.

4. An apparatus according to claim 1, further comprising exactly four elongate members.

5. An apparatus according to claim 1, wherein the planar surface and elongate members are wood.

6. An apparatus according to claim 1, wherein the length of each of the elongate members is approximately equal to the distance between the knee and the ankle of an adult human leg.

7. An apparatus according to claim 1, wherein the area of the planar surface is approximately equal to the area of the back surface of an adult human buttock.

\* \* \* \* \*